

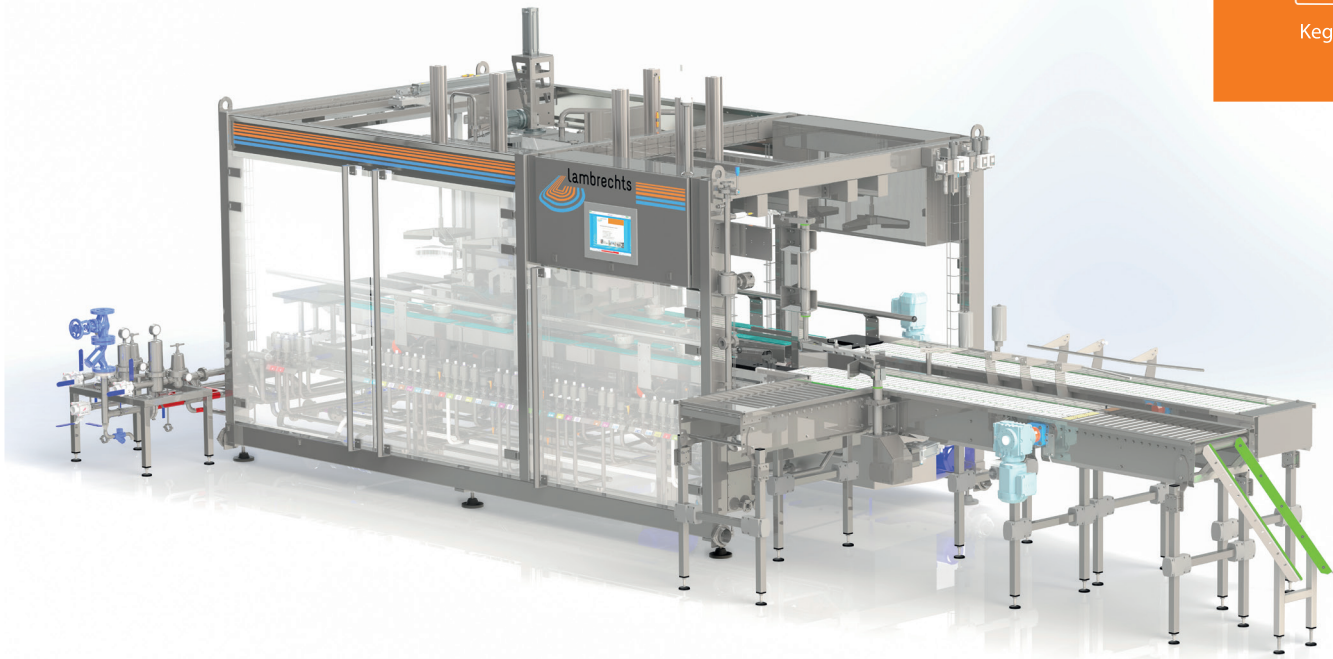

Kegs



60 > 100 kph

Monobloc 80 4-1/5-1/4-2

Semi-automatic washer & filler for kegs

The Keg Cleaning and Filling Solutions for High-Volume Breweries

Automatic process flow

Streamlined and efficient workflow

User-friendly control panel

15" HMI color display provides all process and alarm information in an accessible format

Accessible and easy to maintain

Designed for easy installation and upkeep, with a compact and efficient layout

Compact design

Space-saving dimensions; 4055 x 2160 x 2676 mm (WxDxH).
Small footprint

Processes up to 60-90 kph

Capable of processing 60-100 kegs per hour, ideal for medium to large breweries with high production needs

Compatible with stainless steel kegs

Suitable for kegs ranging from 10 to 60 liters in DIN and European standards

Technology

Integrated media management: Hot water, detergent set, and multiple media tanks

Automated filling system with CO₂ pre-pressurisation and automatic shut-off control

Remote service capabilities, allowing for remote diagnostics and system monitoring

Process

Process monitoring with sensors and self-monitoring controls

Hygienic design

Low CO₂ loss

Noise level below 80dBA

Secured by glass panels to prevent unauthorized access during operation

Construction

Compact design: 4055 x 2160 x 2676 mm (WxDxH)

Robust stainless steel frame

Fully wired and piped, delivered ready for connection and operation

Enclosed within glass panels for operator safety

Foam-cleaning ready for optimal hygiene

PLC control

Integrated electrical cabinet with display controls

2 to 4 active washing heads

1 filling head with auto shut off control

Power requirements: 230/400 V, 50/60 Hz, 4-12 kW

Empty weight: Empty weight of 3600 kg, production weight of 4200 kg

Applications

Suitable for 10 to 60-liter kegs (DIN and European standards)

Stainless steel kegs

One way kegs without bag

Processes up to 60-100 kph

Benefits

Automatic process flow

Easy installation and maintenance

Accessible and user-friendly

Space-saving design without compromising performance

Options

2nd filling head

Caustic spray on fitting and rim side

Automatic detergent dosing system

Flow meter with automatic back-pressure control unit (BPCU)

Auxiliary machines (weigher, turner, coder, keg conveying,...)

Integrated weighing scale

Exterior washing

Reject module

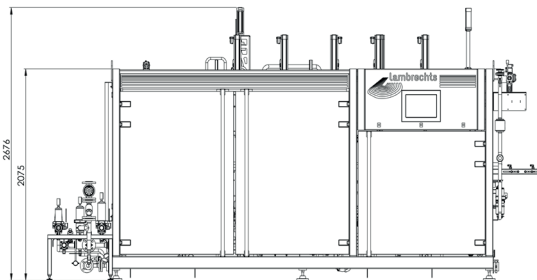
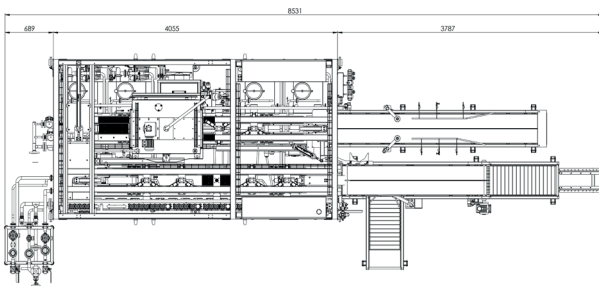
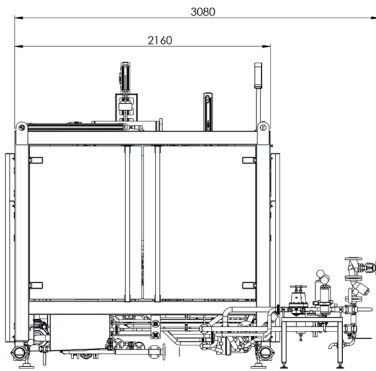

	Monobloc 80 4-1/5-1	Monobloc 80 4-2
Capacity	60 > 75 kph	80 > 100 kph
Wash head	4 to 5	4
Fill head	1	2
2m powered infeed conveyor/ 2m gravity outfeed conveyor	x	x
Integrated hot water, detergent set & mixed water	x	x
Soaking	Up to 5 minutes (optional 20 min)	3,5 minutes
Filling stainless steel kegs	x	x
Filling one way kegs without bag	x	x
Dimensions	4055x2160x2676 mm (WxDxH)	4055x2160x2676 mm (WxDxH)
Detergent tanks	4 integrated tanks	4 integrated tanks (up to 5 in option)