

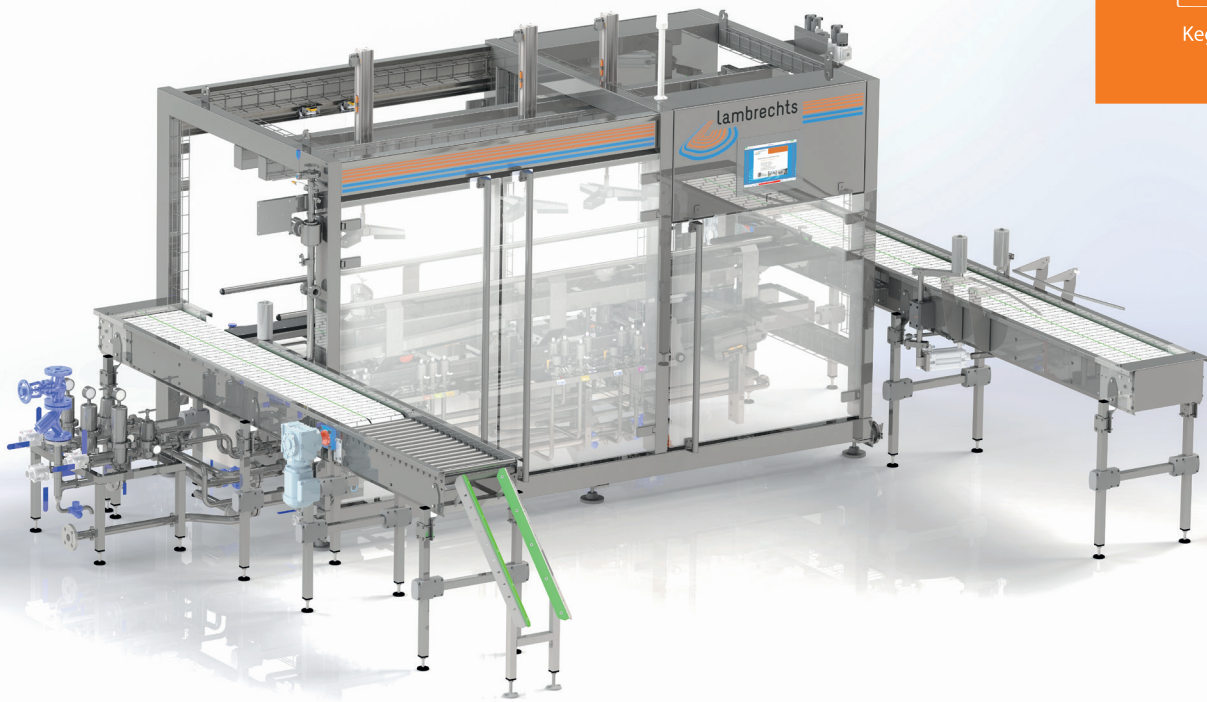

Kegs



50 > 60 kph

Slimline 50 2-1

Semi-automatic washer & filler for kegs

Keg Cleaning Solution for Small to Medium Breweries

Automatic process flow

Streamlined and efficient work-flow

User-friendly control panel

15" HMI color display provides all process and alarm information in an accessible format

Accessible and easy to maintain

Designed for easy installation and upkeep, with a compact and efficient layout

Compact design

Space-saving dimensions; 3369 x 1857 x 2666 mm (WxDxH).
Small footprint

Processes up to 50-60 kph

Ideal for breweries with mid-range production volumes.

Compatible with stainless steel kegs

Suitable for kegs ranging from 10 to 60 liters in DIN and European standards



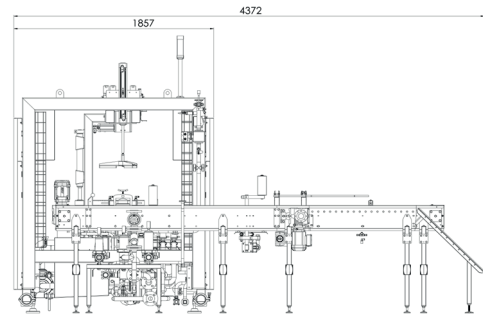
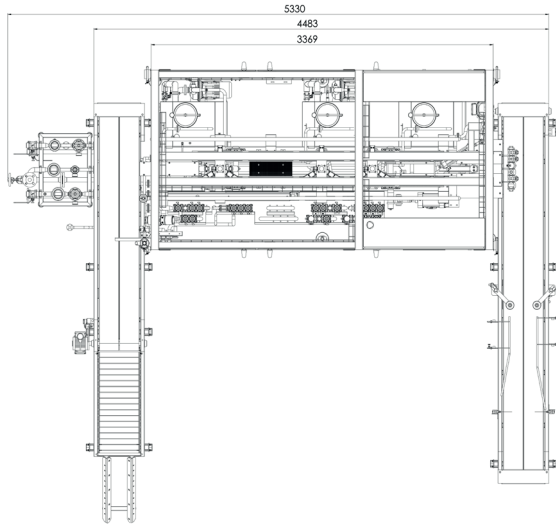
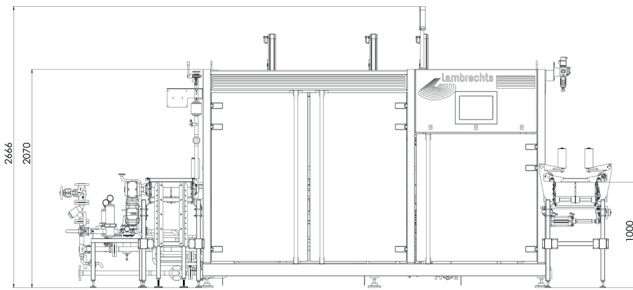

Technology

- Integrated media management: Hot water, detergent set, and multiple media tanks
- Automated filling system with CO₂ pre-pressurisation and automatic shut-off control
- Remote service capabilities for remote diagnostics and system monitoring

Process

- Process monitoring with sensors and self-monitoring controls
- Hygienic design
- Low CO₂ loss
- Noise level below 80dBA
- Secured with glass panels to prevent unauthorized access during operation

Construction

- Compact design: 3369 x 1857 x 2666 mm (WxDxH)
- Space-efficient with a single stainless-steel base frame
- Fully wired and piped, delivered ready for connection and operation
- Enclosed within glass panels for operator safety
- Foam-cleaning ready, ideal for maintaining hygiene standards
- PLC control
- Integrated electrical cabinet with display controls
- 2 to 4 active washing heads
- 1 filling head with auto shut-off control
- Power requirements: 230/400 V, 50/60 Hz, 4-12 kW
- Empty weight: 2300 kg, Production: 2750 kg

Applications

- Suitable for kegs from 10 to 60 litres (DIN and European standards)
- Stainless steel keg
- One way kegs without bag
- Processes up to 50-60kph

Benefits

- Automatic process flow
- Easy installation and maintenance
- Accessible and user-friendly design
- Space-saving installation without compromising performance

Options

- Automatic detergent dosing system
- Flow meter with automatic back pressure control unit (BPCU)
- Auxiliary machines (weigher, turner, coder, keg conveying,...)
- Integrated weighing scale
- Reject module

Efficiency Meets Versatility in Keg Washing and Filling

The Slimline 50 Type 2-1 is an advanced system designed to help breweries scale their production efficiently without sacrificing quality. From streamlined cleaning to precise filling, this machine is a workhorse for mid-sized operations.

